



**R14xxET R1570ET 19" & DT14xxET
DT1570ET DeskTop HV Power Supplies**

Rev. 10 - 3 July 2019

Purpose of this Manual

This document is the R14xxET R1570ET 19" & DT14xxET DT1570ET DeskTop HV Power Supplies User's Manual; it contains information about the installation, the configuration and the use of the Power Supply System.

Change Document Record

Date	Revision	Changes
9 January 2015	0	Preliminary
2 March 2015	1	Updated images
22 June 2015	2	HV Channel Output updated
2 December 2015	3	EPICS Service description
12 February 2016	4	Updated Technical specs. Table
27 May 2016	5	Updated Technical specs. Table, Internal Settings, Initial inspection
17 January 2017	6	Updated hardware KILL description
9 March 2017	7	Updated USB communication
25 March 2019	8	Updated with data for 1570 series
3 April 2019	9	Updated coefficient table page 9
3 July 2019	10	Updated Polarity selection, Ethernet configuration

Disclaimer

No part of this manual may be reproduced in any form or by any means, electronic, mechanical, recording, or otherwise, without the prior written permission of CAEN SpA.

CAEN will repair or replace any product within the guarantee period if the Guarantor declares that the product is defective due to workmanship or materials and has not been caused by mishandling, negligence on behalf of the User, accident or any abnormal conditions or operations.

CAEN declines all responsibility for damages or injuries caused by an improper use of the Modules due to negligence on behalf of the User. It is strongly recommended to read thoroughly the CAEN User's Manual before any kind of operation. *CAEN reserves the right to change partially or entirely the contents of this Manual at any time and without giving any notice.*

Disposal of the Product *The product must never be dumped in the Municipal Waste. Please check your local regulations for disposal of electronics products.*

Made In Italy : We stress the fact that all the boards are made in Italy because in this globalized world, where getting the lowest possible price for products sometimes translates into poor pay and working conditions for the people who make them, at least you know that who made your board was reasonably paid and worked in a safe environment. (this obviously applies only to the boards marked "Made in Italy", we cannot attest to the manufacturing process of "third party" boards).

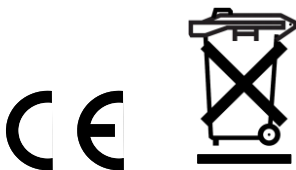

Index

1. General description	5
Overview	5
2. Technical specifications	6
Packaging	6
Power requirements	6
Front panel	6
External connections	7
Local control section	7
Channel control and output section	7
Channel control	7
Kill signal	8
HV Channel Output	8
HV Status control section	9
Alarm signal	9
Interlock signal	10
Remote communication control section	11
AC Input (back plane)	11
Technical specifications table	12
Imon Zoom	13
3. Operating modes	14
Safety requirements	14
Initial inspection and installation	14
Local Control	15
BOARD Settings	16
Ethernet settings	16
Channel settings	17
Group Settings	18
Status Icon	19
Current monitor offset calibration	19
Remote Control	20
USB communication	20
Ethernet communication	20
Ethernet configuration	21
Firmware upgrade	22
Format EEPROM	23
Channels settings	23
Board Status	23
Communication Protocol	24
Command Format	24
Format of response string	24
MONITOR commands related to the Channels	24
Meaning of STATUS bits (value read in decimal Format)	25
MONITOR commands related to the module	25
Meaning of Board Alarm bits	26
SET commands related to the Channels	26
SET commands related to the module	26
EPICS Service	26
4. Internal Settings	27
Polarity selection	27
Grounding specifications	29
Safety Earth connection	29

List of Figures

Fig. 1: Mod. R14xx-1570ET and DT14xx-1570ET	5
Fig. 2: DT14xxET Front panel	6
Fig. 3: R14xxET Front panel (4 channel)	6
Fig. 4: R14xxET Front panel (8 channel)	6
Fig. 5: DT1570ET Front panel	6
Fig. 6: R1570ET Front panel (4 channel)	6

Fig. 7: Local control panel	7
Fig. 8: Channel control panel and Kill scheme	7
Fig. 9: KILL electrical scheme	8
Fig. 10: HV Channel panel and test point electrical scheme	8
Fig. 11: HV Status control panel.....	9
Fig. 12: ALARM electrical scheme	9
Fig. 13: ALARM TTL configured	10
Fig. 14: INTERLOCK electrical scheme.....	10
Fig. 15: Remote communication control and RS485 I/O – RS232 IN electrical scheme.....	11
Fig. 16: AC Input socket	11
Fig. 17: Main Menu.....	15
Fig. 18: Board Parameters	16
Fig. 19: Channel Parameters.....	17
Fig. 20: Virtual keypad	17
Fig. 21: Group Parameters.....	18
Fig. 22: Zoom Mode.....	18
Fig. 23: USB communication diagram	20
Fig. 24: Ethernet communication diagram	20
Fig. 25: Terminal Board Menu	21
Fig. 26: Terminal Ethernet settings.....	21
Fig. 27: Terminal Ethernet connection	22
Fig. 28: Firmware Upgrade Menu	22
Fig. 29: Format EEPROM Menu	23
Fig. 30: Channels Menu	23
Fig. 31: General Board Status	23
Fig. 32: Polarity selection instructions	28
Fig. 33: C21 jumper location.....	29
Fig. 34: Earth configuration connection examples	29

List of Tables

Table 1: Available versions	5
Table 2: Kill operation.....	8
Table 3: Interlock operation	10
Table 4: Mod. R-DT14xxET – 1570ET Series technical specifications.....	12

1. General description

Overview



Fig. 1: Mod. R14xx-1570ET and DT14xx-1570ET

This HV power supply family provides 2, 4 or 8 independent High Voltage channels in either 19" rack unit package or Desktop format. The units are 110/220V AC Powered; five output ranges are available.

Table 1: Available versions

Series	1419	1470	1471	1471H	1570
V Full Scale (kV)	± 0.5	± 8	± 5.5	± 5.5	±15
I Full Scale (mA)	0.2	3 (@3kV)	0.3	0.02	1
Vset/Vmon resolution (V)	0.05	0.2	0.1	0.1	500
Ramp UP/DOWN full scale (V/s)	50	500	500	500	500
Iset/Imon (H) resolution (nA)	5 Iset/Imon	50 Iset/Imon	5 Iset/Imon	1 Iset/Imon	20 Iset/Imon
Imon (L) resolution (nA)	0.5 Imon	5 Imon	0.5 Imon	0.05 Imon	2Imon
Output Connectors	SHV	SHV	SHV	SHV	HV LEMO
Available format	19" 4-8ch; DT 4ch	19" 4-8ch; DT 4ch	19" 4-8ch; DT 4ch	19" 4-8ch; DT 4ch	19" 2-4ch; DT 2ch

Module control can take place either locally, assisted by a 2.8" Touchscreen Graphic color LCD display or remotely, via USB, or Ethernet, the latter allowing to build a daisy chain network. The output polarity is independently selectable for each channel.

Channels have common floating return (common return insulated from the crate ground), that can be configured as "common ground" (see p.29); HV outputs are delivered through SHV connectors (HV LEMO for 1570 series).

Safety features include:



- OVERVOLTAGE and UNDERVOLTAGE warning when the output voltage differs from the programmed value by more than 2% of set value (minimum 10V).
- Programmable VMAX protection limit
- OVERCURRENT detection: if a channel tries to draw a current larger than its programmed limit, it enters TRIP status, keeping the maximum allowed value for a programmable time (TRIP), before being switched off
- Common Interlock logic for channels enable/disable and individual inputs signal for channel Kill function.



2. Technical specifications



Packaging

- 19" rack package (height: 2U; depth: 360mm). Weight: ~9kg (2-4 ch), 10.5kg (8 ch).
- Desktop package (239x84x184mm); Weight: ~5.2kg.

Power requirements

2 Channels:
INPUT: VOLTAGE 100 - 240 V  
FREQUENCY 50 / 60 Hz
CURRENT 0.6A RMS MAX
FUSE 2 x T1A 6.3x32 250VAC

4 Channels:
INPUT: VOLTAGE 100 - 240 V  
FREQUENCY 50 / 60 Hz
CURRENT 0.8A RMS MAX
FUSE 2 x T1A 6.3x32 250VAC

8 Channels:
INPUT: VOLTAGE 100 - 240 V  
FREQUENCY 50 / 60 Hz
CURRENT 1.6A RMS MAX
FUSE 2 x T2A 6.3x32 250VAC

Front panel



Fig. 2: DT14xxET Front panel



Fig. 3: R14xxET Front panel (4 channel)



Fig. 4: R14xxET Front panel (8 channel)



Fig. 5: DT1570ET Front panel



Fig. 6: R1570ET Front panel (4 channel)

External connections

Local control section



Fig. 7: Local control panel

NAME:	TYPE:	FUNCTION:
MONITOR	2.8" LED Touch Screen	Parameter and Mode setting; Local settings monitoring

Channel control and output section

Channel control

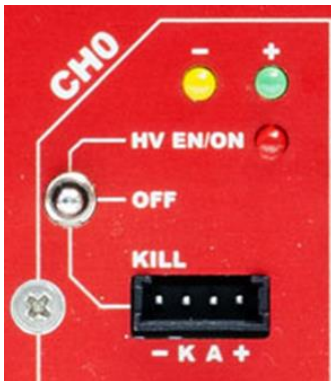

Fig. 8: Channel control panel and Kill scheme

NAME:	TYPE:	FUNCTION:
HV_EN/OFF/KILL ON	3 POS. SWITCH RED LED	Channel Enable and turning OFF/KILL HV On enabled
+	GREEN LED	Positive polarity
-	YELLOW LED	Negative polarity
REMOTE KILL	AMP 280371-2	See below

Kill signal

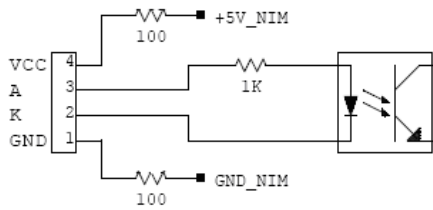

Fig. 9: KILL electrical scheme

A schematic diagram of the Kill input is shown in the figure above, where the diode is part of opto-coupler stage. Kill means that channels are hardware turned off. The following table explains the Kill operation:

Table 2: Kill operation

CONFIGURATION ↓	KILL MODE →	OPEN	CLOSE
leave contact open		Killed	ENABLED
voltage level (0÷1V, ~5mA current) between pin 2 and pin 3		Killed	ENABLED
short circuit pin 1 with pin 2, and pin 3 with pin 4		ENABLED	Killed
voltage level (4÷6V, ~5mA current) between pin 2 and pin 3		ENABLED	Killed

HV Channel Output



Fig. 10: HV Channel panel and test point electrical scheme

NAME:	TYPE:	FUNCTION:
MON	AMP 280371-2	<i>Vout/Iout Test point</i>
OUT	1419, 1470, 1471, 1471H SHV RADIALL R317580 Impedance: 50 Ohm; Frequency range: 0 – 2 GHz; VSWR: <1.20 + 0.3 F (GHz) – (plug and jack); Test voltage: 10kV DC – 1mn (unmated connectors); Ratings: 12kV DC – 1mn (mated pairs); Current rating: 10 A	<i>HV Channel Output</i>
	1570 LEMO HV ERA3S415CTL Endurance (Shell): 5000 mating cycles, Temp (min / max): -55°C / +250°C, Humidity (max): <=95% [at 60 deg C /140 F], Vibration: 15 g [10 Hz - 2000 Hz], Shock Resistance: 100 g [6 ms], Salt Spray Corrosion: >144 hr, Climatical Category: 50/175/21 Shielding (min): 75 dB (10 MHz) Shielding (min): 40 dB (1 GHz), IP Rating: 50	



WARNING! These connectors produce extremely hazardous high voltages at a potentially lethal current level; never connect or disconnect the HV OUT connector with the power ON/OFF switch ON; always switch power OFF and wait at least 30s before connecting or disconnecting HV cables.

The test points allow to monitor the Channel Output Voltage and Current according to the following conversion:

VMON	R-DT1419ET	Voltage level	1V = 118 V ±1% readout; same polarity as channel
	R-DT1470ET		1V = 1.8V ±1% readout; same polarity as channel
	R-DT1471ET		1V = 1.5 kV ±1% readout; same polarity as channel
	R-DT1471HET		1V = 1.5 kV ±1% readout; same polarity as channel
	R-DT1570ET		1V = 4 kV ±1% readout; same polarity as channel
IMON HI RANGE	R-DT1419ET		1V = 67 µA ±3% readout; positive, 0÷5 V range
	R-DT1470ET		1V = 660 µA ±3% readout; positive, 0÷5 V range
	R-DT1471ET		1V = 66 µA ±3% readout; positive, 0÷5 V range
	R-DT1471HET		1V = 4.55 µA ±3% readout; positive, 0÷5 V range
	R-DT1570ET		1V = 260 µA ±3% readout; positive, 0÷5 V range
IMON LOW RANGE	R-DT1419ET		1V = 6.7 µA ±3% readout; positive, 0÷5 V range
	R-DT1470ET		1V = 66 µA ±3% readout; positive, 0÷5 V range
	R-DT1471ET		1V = 6.6 µA ±3% readout; positive, 0÷5 V range
	R-DT1471HET		1V = 455 nA ±3% readout; positive, 0÷5 V range
	R-DT1570ET		1V = 26 µA ±3% readout; positive, 0÷5 V range

HV Status control section



Fig. 11: HV Status control panel

NAME:	TYPE:	SIGNAL:	FUNCTION:
ON	RED LED		HV On enabled (at least one channel ON)
ALARM	RED LED/ AMP 280371-2.	Out	Alarm status signalled (active LOW)
INTERLOCK	RED LED/ AMP 280371-2	In	Interlock signal

Alarm signal

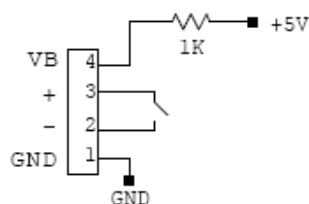

Fig. 12: ALARM electrical scheme

As an Alarm condition is detected (see p. 25 and 26) pins 2 and 3 (- and +) are closed; the contact can be used to switch an external device supplied by an external source, otherwise the VB and GND references can be used to provide a TTL compatible level on pin 2 and 3.

In the first case (externally supplied device) the maximum allowed ratings are:

- Maximum voltage between + and -: 12V
- Maximum sink current across + and -: 100mA

In the latter case, to produce a TTL compatible Alarm Out, pin 3 (+) must be connected with pin 4 (VB) and pin 1 (GND) with pin 2 (-); see the diagram below:

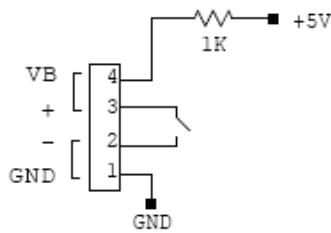

Fig. 13: ALARM TTL configured

Interlock signal

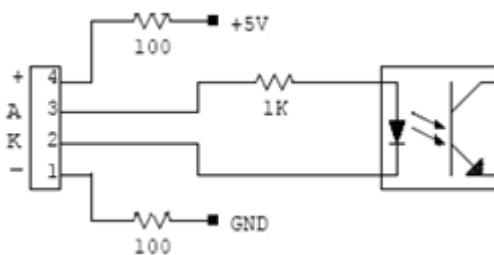

Fig. 14: INTERLOCK electrical scheme

A schematic diagram of the Interlock input is shown in the figure above, where the diode is part of optocoupler stage.

Interlock means that channels are hardware disabled. The following table explains the interlock operation:

Table 3: Interlock operation

CONFIGURATION ↓	INTERLOCK MODE →	OPEN	CLOSE
leave contact open		INTERLOCK	ENABLED
voltage level (0÷1V, ~5mA current) between pin 2 and pin 3		INTERLOCK	ENABLED
short circuit pin 1 with pin 2, and pin 3 with pin 4		ENABLED	INTERLOCK
voltage level (4÷6V, ~5mA current) between pin 2 and pin 3		ENABLED	INTERLOCK

The front panel Interlock LED is ON when the INTERLOCK is active; as INTERLOCK is active, channels are turned off at the fastest available rate, regardless the RAMP DOWN setting.

Remote communication control section

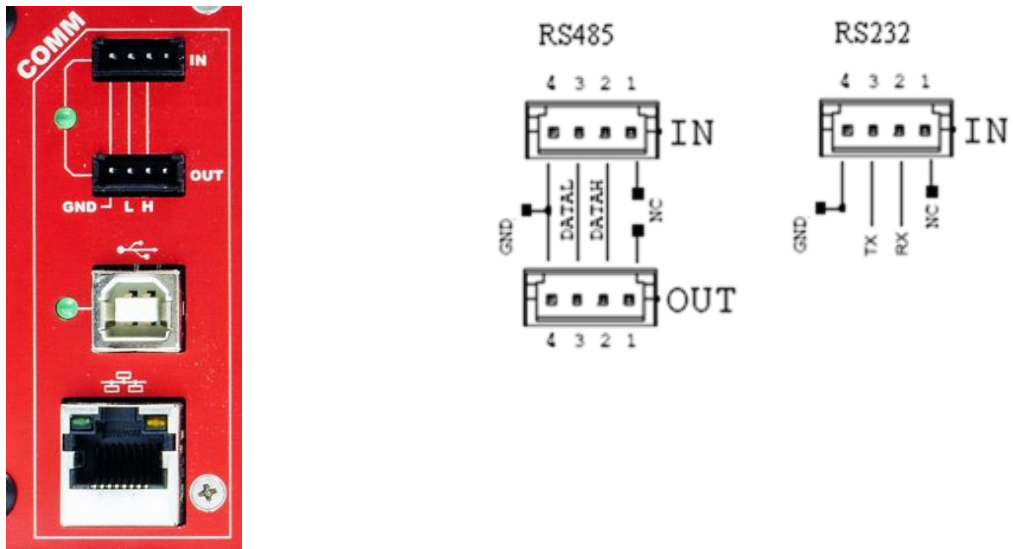

Fig. 15: Remote communication control and RS485 I/O – RS232 IN electrical scheme

NAME:	TYPE:	FUNCTION:
IN	AMP 280371-2	RS485 Input ¹ ;
OUT	AMP 280371-2	RS485 Output
USB	B TYPE USB	USB2.0 compliant
ETH	10Base-T female connector	TTL signals (TCP/IP)

AC Input (back plane)



Fig. 16: AC Input socket

IEC 60 320 Socket with switch; to be connected to Mains 100 - 240 Vac (50 - 60 Hz) via provided power cord.

Two Fuses: 6.3x32 (2/4 channels: 1A, 8 channels: 2A); Retarded 250VAC

¹ RS 485 Serial Port Interface allows to control up to 32 modules connected by a twisted pair cable; the first and last modules must be terminated, see p.36; this feature is not available on Mod. R1470ETD - (8 Channel)

Technical specifications table

Table 4: Mod. R-DT14xxET – 1570ET Series technical specifications

Series	1419		1471H		1471	1470		1570					
Packaging	19" rack (h: 2U; d: 360mm). Weight: ~9kg (2-4 ch), 10.5kg (8 ch); Desktop package (239x84x184mm); Weight: ~5.2kg												
Power requirements	100–240V ~ 50/60Hz; 2 ch.: 0.6A RMS; fuse 2xT1A 6.3x32 250VAC; 4 ch.: 0.8A RMS; fuse 2xT1A 6.3x32 250VAC; 8 ch.: 1.6A RMS; fuse 2xT2A 6.3x32 250VAC												
Output channels	Positive or Negative Polarity (requires internal setting, see p. 27)												
Output ranges	500 V / 200µA		5.5kV / 20µA		5.5kV / 300µA		8 kV / 3 mA		15 kV / 1mA				
Max. Ch. Output Power	0.1W		0.11W		1.65W		9 W (Vset ≤ 3 kV) 8 W (Vset > 3 kV)		10W (<10kV) 7W (>10kV)				
Vset / Vmon Resolution	10 mV		100 mV			200 mV		400 mV					
Iset Resolution	5 nA		1 nA		5 nA		50 nA		20 nA				
Imon Resolution	IMON RNG H		5 nA		1 nA		5nA		50 nA				
	IMON RNG L		500pA		50pA		500pA		5 nA				
Vmax	0 ÷ 510 V		0 ÷ 5600 V			0 ÷ 8100 V		0 ÷ 15100 V					
	Absolute maximum HV level that the channel is allowed to reach, independently from the preset value Vset. Output voltage cannot exceed the preset value Vmax. The accuracy is 1 % ± 5 V												
Vmax resolution	± 0.1 V		± 1 V										
Alarm output	Open collector, 100 mA maximum sink current												
Interlock input	LOW: <1V; current~5mA; HIGH: 4÷6 V												
Ramp Up/Down	1÷50 Volt/s, 1 Volt/s step			1÷500 Volt/s, 1 Volt/s step									
Trip	Max. time an "overcurrent" is allowed to last (seconds). A channel in "overcurrent" works as a current generator; output voltage varies in order to keep the output current lower than the programmed value. "Overcurrent" lasting more than set value (1 to 9999) causes the channel to "trip". Output voltage will drop to zero either at the Ramp-down rate or at the fastest available rate, depending on Power Down setting; in both cases the channel is put in the off state. If trip= INFINITE, "overcurrent" lasts indefinitely. TRIP range: 0 ÷ 999.9 s; 1000 s = Infinite. Step = 0.1 s												
Accuracy ²	Vmon vs. Vout		±0.02% of read value ±0.2V			±0.02% of read value ±2V							
	Vset vs. Vout		±0.02% of set value ±0.2V			±0.02% of set value ±2V							
	Imon vs. Iout	IMON RNG H		±2% of read ±20nA		±2% of read ±2nA		±2% of read ±20nA		±2% of read ±2µA			
		IMON RNG L		±2% of read ±2nA		±2% of read ±200pA		±2% of read ±2nA		±2% of read ±200nA			
	Iset vs. Imon	IMON RNG H		±2% of read ±30nA		±2% of read ±3nA		±2% of read ±30nA		±2% of read ±2µA			
IMON RNG L		±2% of read ±3nA		±2% of read ±300pA		±2% of read ±3nA		±2% of read ±200nA					
Voltage Ripple ³	Typical			<3mVpp		<5mVpp		<5mVpp		3kV/200µA			
								<10mVpp		4÷8kV/200µA		<5mVpp	7kV/250µA
										3kV/3mA 4kV/2mA		<10mVpp	
	Maximum		<5mVpp		<10mVpp		<20mVpp		3kV/200µA	4÷8kV/200µA			
							<30mVpp		6kV/1mA 8kV/800µA		<20mVpp		14kV/500µA
									3kV/3mA 4kV/2mA		<15mVpp		10kV/350µA
						<25mVpp		6kV/1mA 8kV/800µA	14kV/500µA				
Ventilation Fan	60x60 24V; 62 dBA maximum noise level												
Humidity range	0 ÷ 80%												
Operating temperature	0 ÷ 45°C												
Storage temperature	-10 ÷ 70°C												
Vout / Temp. coefficient	max. 50ppm / °C												
Imon / Temp. coefficient	max 100ppm/C°; max 300ppm/C° with Imon zoom ⁴												
Longterm stability Vout vs. Vset	± 0.02% (after one week @ constant temperature)												

² Accuracy values are measured from 10% to 90% of Full Scale Range

³ Measured with: 1m cable length; 2nF capacitance, 100MHz band width

⁴ Typical data (for series 1470ET) IMON: Imon-Zoom Offset = ±100nA; ppm/C° Imon-Zoom <300ppm/C°; Imon leakage +5nA/2kV

Imon Zoom

Imon Zoom is a feature that allows to monitor the channel current with an increased resolution in the following ranges:

1419	0 – 20 μ A
1470	0 – 300 μ A
1471	0 – 30 μ A
1471H	0 - 2 μ A
1570	0 – 100 μ A

by selecting Imon Range = LOW, the output current is monitored with

1419	500 pA resolution (instead of 5 nA), in the 0 – 20 μ A range
1470	5 nA resolution (instead of 50 nA), in the 0 – 300 μ A range
1471	500 pA resolution (instead of 5 nA), in the 0 – 30 μ A range
1471H	50 pA resolution (instead of 1 nA), in the 0 - 2 μ A range
1570	2 nA resolution (instead of 20 nA), in the 0 – 100 μ A range

It is important to notice that, if Imon Range = LOW is selected, and the channel draws a current larger than

20 μ A	1419
300 μ A	1470
30 μ A	1471
2 μ A	1471H
100 μ A	1570

then Overcurrent is signalled.

3. Operating modes

Safety requirements

N.B. read carefully the “Precautions for Handling, Storage and Installation” document provided with the product before starting any operation!

The following HAZARD SYMBOLS are reported on the unit:



CAUTION: indicates the need to consult the “Precautions for Handling, Storage and Installation” document provided with the product. **A potential risk exists if the operating instructions are not followed**



HIGH VOLTAGE: indicates the presence of electric shock hazards. Enclosures marked with these symbols should only be opened by CAEN authorized personnel.

To avoid risk of injury from electric shock, do not open this enclosure

To avoid potential hazards, use the product only as specified. Only qualified personnel should perform service procedures.

Avoid Electric Overload. To avoid electric shock or fire hazard, do not power a load outside of its specified range.

Avoid Electric Shock. To avoid injury or loss of life, do not connect or disconnect cables while they are connected to a voltage source.

Do Not Operate without Covers. To avoid electric shock or fire hazard, do not operate this product with covers or panels removed.

Do Not Operate in Wet/Damp Conditions. To avoid electric shock, do not operate this product in wet or damp conditions.

Do Not Operate in an Explosive Atmosphere. To avoid injury or fire hazard, do not operate this product in an explosive atmosphere.

Do Not Operate with Suspected Failures. If you suspect this product to be damaged, have it inspected by qualified service personnel.

Initial inspection and installation

Prior to shipment, these units are inspected and found free of mechanical or electrical defects. Upon unpacking of the unit, inspect for any damage, which may have occurred in transport. The inspection should confirm that there is no exterior damage to the unit, such as broken knobs or connectors, and that the panels are not scratched or cracked. Keep all packing material until the inspection has been completed. If damage is detected, file a claim with carrier immediately and notify CAEN. Before installing the unit, make sure you have read thoroughly the safety rules and installation requirements, then place the package content onto your bench; you shall find the following parts:

- Rack 19" or Desktop HV Power Supply;
- AC/DC power supply
- USB cable
- 10 BASE-T Ethernet cable

R14xxET's – R1570ET's are housed in 19" rack package. The R14xxET– R1570ET is an equipment for BUILDING-IN: it must be installed in a 19" EIA compliant equipment rack. Use the front panel rack-mount brackets to install the unit in the rack, using standard screws; leave at least one rack unit of free space above and below the Unit.

DT14xxET's DT1570ET's are housed in a Desktop package. The DT14xxET– DT1570ET is an equipment for BUILDING-IN: it must be used on flat solid surfaces, such as a table.

Unit control can take place either locally, assisted by a 2.8" Touchscreen LCD or remotely, via USB, or Ethernet (see p. 20).

Local Control

To turn ON the unit, connect the unit to the Mains through the power cord, provided with the kit, and switch it ON. At power ON the Display shows the Main Menu:

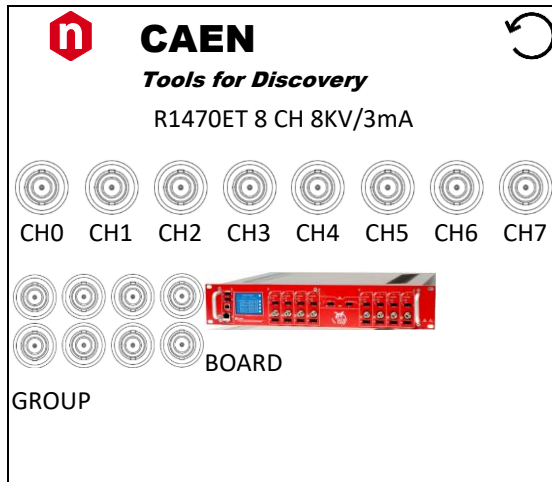

Fig. 17: Main Menu

At this point the module is ready to be operated locally. Tap on:

- BOARD icon to access BOARD parameters
- CHx icon to access CHANNELS parameters
- GROUP icon to access CHANNEL GROUP parameters

BOARD Settings

Board Parameters	
Power	√
RTerm	Off
HV Clock	√
LBusBaud	9600
LBusAddr	0
Interlock	Closed
Control	Remote
←	

Fig. 18: Board Parameters

General board parameters (CONTROL can be operated both in LOCAL and REMOTE mode; other settings are allowed in LOCAL mode only; monitor options are available also with remote control) include:

Parameter:	Type:	Function:
Power	Monitor	Module power supply status
Termination	Monitor	Local Bus termination status (ON/OFF)
HV Clock	Monitor	Sync clock frequency (200±10 kHz correct value)
Local Bus Baud Rate	Monitor/Set	9600, 19200, 38400, 57600, 115200 Baud
Local Bus Address	Monitor/Set	Local Bus address for remote communication (0÷31)
INTERLOCK	Monitor/Set	CLOSED / OPEN OPERATION (see p.10)
CONTROL	Monitor/Set	REMOTE: the module is controlled remotely; local monitor is allowed; LOCAL/REMOTE switch is enabled

LOCAL: the module is controlled locally; remote monitor is allowed

To set one parameter, set Control to “Local”, then tap on the relevant name, and change and/or enter the desired value; confirm with “Enter”.

Tapping the red arrow, allows to go back.

Tapping “Network” Icon allows to access Ethernet configuration menu:

Ethernet settings

Ethernet Config. Menu <
IPAddress
010.000.007.061
Mask
255.000.000.000
Gateway
255.255.255.255
√ >

MAC Address
010.000.000.000
DHCP
Disabled
√ >

This option allows to configure the Ethernet settings; once they are done, tap Mark icon to Save, but changes will only become effective at next power ON. Tap the red arrows to go forward and back.

If a DHCP Server is available, then the module can be enabled or disabled as DHCP client; tap green button to save the new setting and go back to Main Menu: the DHCP server will automatically assign a new IP to the module at next Power On. Tap the backward red arrow to go back without changes.

Channel settings

(-) CH1 MENU ←		(-) CH1 MENU ←	
VMon	0000.0	MaxV	8100
IMon	0000.00	RampUp	500
Status	Kill !	RampDown	400
VSet	2000.0	Trip	INF
ISet	3100.00	PowerDown	Kill
Chan	1/2	IMonRange	High
		Chan	2/2

Fig. 19: Channel Parameters

For each channel the following parameters can be programmed and monitored either locally or remotely (see p.20):

Parameter:	Function:	Unit:
(±)	Channel polarity	
Vmon	High Voltage Monitored value	Volt
Imon	Current Monitored value	µA
Status	ON/OFF; Ramp UP/DOWN; OVV; UNV; OVC; OVP; MAXV; TRIP; OVT; OFF; KILL; ILK; CAL_ERR	
Vset	High Voltage programmed value	Volt
Iset	Current Limit programmed value	µA
MaxV	Absolute maximum High Voltage level that the channel can reach (see p. 12)	V
Ramp-Up	Maximum High Voltage increase rate	V/s
Ramp-Down	Maximum High Voltage decrease rate	V/s
Power Down	Power Down mode after channel TRIP	KILL or RAMP
Trip	Max time "overcurrent" allowed to last (1000 = ∞)	s
Imon Range	Current Monitor Zoom	H or L

To set one parameter, tap on the relevant name, and change and/or enter the desired value through the “virtual keypad” (see below); confirm with “Enter”. Tap the red arrow to go back to Main Menu.

1	2	3
4	5	6
7	8	9
.	0	Del
Enter		

Fig. 20: Virtual keypad

Group Settings

GROUP MENU ←				GROUP MENU ←	
Ch	VMon	IMon	Status		
0(-)	1500.0	0000.00	On v	MaxV	8100
1(-)	0000.0	0000.00	Off v	RampUp	500
2(-)	0000.0	0000.00	Off v	RampDown	400
3(-)	0000.0	0000.00	Off v	Trip	INF
Zoom				RampDown	400
VSet				PowerDown	Kill
ISet				IMonRange	High
Chan		1/2		Chan	2/2

Fig. 21: Group Parameters

For the Group of all channels, the following parameters can be programmed and monitored either locally or remotely (see p.20):

Parameter:	Function:	Unit:
Vmon	High Voltage Monitored value single channels	Volt
Imon	Current Monitored value single channels	µA
Status	ON/OFF; Ramp UP/DOWN; OV; UNV; OVC; OVP; MAXV; TRIP; OVT; OFF; KILL; ILK; CAL_ERR single channels	
Vset	High Voltage programmed value	Volt
Iset	Current Limit programmed value	µA
MaxV	Absolute maximum High Voltage level that the channel can reach	V
Ramp-Up	Maximum High Voltage increase rate	V/s
Ramp-Down	Maximum High Voltage decrease rate	V/s
Power Down	Power Down mode after channel TRIP	KILL or RAMP
Trip	Maximum time an "overcurrent" is allowed to last	s
Imon Range	Current Monitor Zoom	H or L

To set one parameter, tap on the relevant name, and change and/or enter the desired value through the "virtual keypad"; confirm with "Enter". Tap the red arrow to go back to Main Menu. "Zoom" option allows to display large sized Vmon and Imon values.

ZOOM MODE ←		
Ch0	5499.2	V
v	0000.00	µA
Ch0	0000.0	V
v	0000.00	µA
Ch0	0000.0	V
v	0000.00	µA
Ch0	0000.0	V
v	0000.00	µA

Fig. 22: Zoom Mode

Status Icon

Three types of Icon in the display status area indicate:

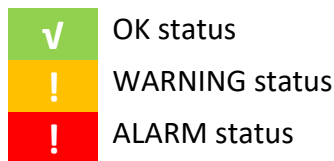

Current monitor offset calibration

The Units are calibrated by introducing a positive offset on the current monitor. This type of calibration allows to monitor very low current thus removing possible issues due to components and working temperatures related negative offsets. The absolute value of delivered current can be quantified by following the steps below:

- 1) Turn on the module, after a warm-up of about 30 minutes with operating voltage and load disconnected (no link between the unit and detectors) then read the monitored current value $I_{mon} = I_1$ (offset)
- 2) Turn off the channel and connect the load
- 3) Turn on the channel with the same voltage set as point 1)
- 4) Wait a few minutes and read again the current value monitor $I_{mon} = I_2$ (offset + I_{out})
- 5) The value of current output is equal to the difference between I_2 and I_1 ($I_{out} = I_2 - I_1$)

Leakage currents equal to:

R-DT1419ET	1nA/100 V		Vout=400V, $I_{mon}=+6nA$ (2nA Offset +4nA current leakage/400V)
R-DT1470ET	5nA/1kV	Shall be	Vout=4kV, $I_{mon}=+30nA$ (10nA Offset +20nA current leakage/4kV)
R-DT1471ET	1nA/500V	tolerated; e.g.	Vout=2kV, $I_{mon}=+6nA$ (2nA Offset +4nA current leakage/2kV)
R-DT1471HET	0.1nA/500V		Vout=2kV, $I_{mon}=+0.6nA$ (0.2nA Offset +0.4nA current leakage/2kV)
R-DT1570ET			

The offset introduced is equal to:

R-DT1419ET	20nA for high range; 2nA for low range
R-DT1470ET	100nA for high range; 10nA for low range
R-DT1471ET	20nA for high range; 2nA for low range
R-DT1471HET	2nA for high range; 0.2nA for low range
R-DT1570ET	

with output voltage at 10% of full scale and 20 °C temperature.

Remote Control

Module control can take place remotely, via USB or Ethernet; the latter allows, using the RS485 I/O's, to build a daisy chain network. To turn ON the unit, connect the unit to the Mains through the provided power cord, and switch it ON; then go to Board menu and set Control > REMOTE (see p. 16).

USB communication

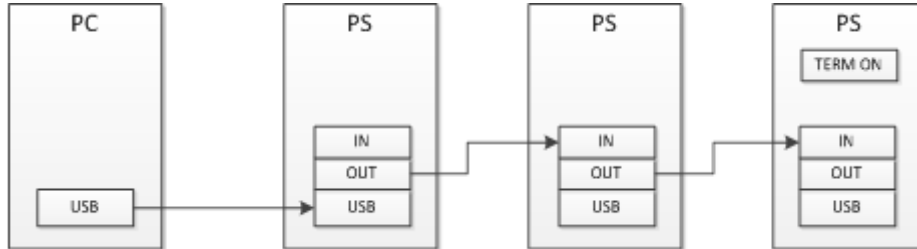

Fig. 23: USB communication diagram

The module is provided with a USB2.0 compliant interface (see p.7). The Unit can be programmed via PC by connecting the PC USB port with the Unit USB B-type port; the relevant drivers, are available from www.caen.it DT14xxET/R14xxET page.

N.B. for Linux OS Users: the Unit is automatically recognised by Kernel Linux 2.6.9 and higher; unit name is assigned to serial port with name `/dev/ttyACM[x]`, where [x] is device number; for example 1st module connected is `/dev/ttyACM0`, 2nd module is `/dev/ttyACM1` etc.

CAEN provides the CAEN GECO2020 Control Software that allows a friendly remote management of all Unit's functional parameters (see www.caen.it software support page); anyway, the connection can be performed also via terminal emulator, such as Tera Term, configured as follows:

- baud rate 9600
- Data bits: 8
- Parity: none
- stop bit: 1
- Flow control: Xon Xoff

As the communication is running, type CAEN, and the main menu will be accessed (see p.21)

It is also possible to build a daisy chain of up to 32 units, with the first module connected to the PC USB port and the subsequent ones daisy chained through the COMM IN/OUT, as explained on p.21 (this feature is not available on Mod. R1470ETD - 8 Channel) ; in this case communication with the chained modules is achieved through the USB - RS485 Communication Protocol, see p.21. All modules must be assigned a LOCAL BUS ADDRESS different from one another and the last one must be terminated (see p.11)

Ethernet communication

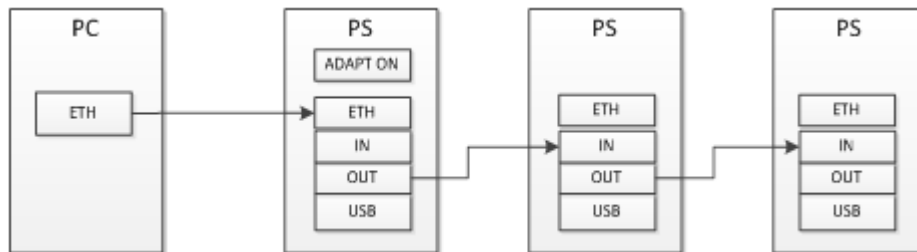

Fig. 24: Ethernet communication diagram

It is possible to communicate via Ethernet with one or more daisy chained DT14xxET/R14xxET modules. Communication via Ethernet is possible only through the USB - RS485 Communication Protocol. It is necessary to connect the 1st module to the PC via Ethernet, then the 1st module to the following using COMM IN/OUT. Daisy chain capability is not available on Mod. R1470ETD - (8 Channel).

CAEN provides the CAEN GECO2020 Control Software that allows a friendly remote management of all Unit's functional parameters (see www.caen.it software support page); anyway, the connection can be performed also via terminal emulator, such as Tera Term.

Ethernet configuration

To configure the Ethernet Port:

- connect to the module via USB as explained in the previous sections
- launch a terminal emulator, such as Tera Term, configured as explained at p.20
- type CAEN
- the following screen will open:

```

#####  #####  ##  ###  #####  ##  #####  #####
##  ##  ##  ###  ##  ##  ##  ##  ##  ##
##  ##  ##  ##  #####  ##  ##  #####  ##
#####  ##  ##  ##  ##  ##  ##  #####  ##

C.A.E.N. DT1471ET4 CH 5.5KV/300uA V1.00 Addr 00

B O A R D   M E N U

Display      Display/Modify channels
Format      Reformat EEPROM
General      General board status
Ethernet     Ethernet configuration
Update      Firmware Update

Quit

Select Item
    
```

Fig. 25: Terminal Board Menu

Type E; the following screen will open:

```

C.A.E.N. DT1471ET 4 CH 5.5KV/300uA Power Supply V1.00 Addr 00

Ethernet Configuration Menu

MACAddress   00  04  a3  a2  57  a7
IPAddress    010 000 006 122
Subnet Mask  255 000 000 000
Gateway      010 000 000 001

_Save   Quit
    
```

Fig. 26: Terminal Ethernet settings

For example, Enter the following settings:

```

IPAddress    010 000 007 060
Subnet Mask  255 000 000 000
Gateway      010 000 000 001
    
```

Type S to save; the Ethernet Port is now ready to work. When accessing via Ethernet select port number 1470; refer to figure:

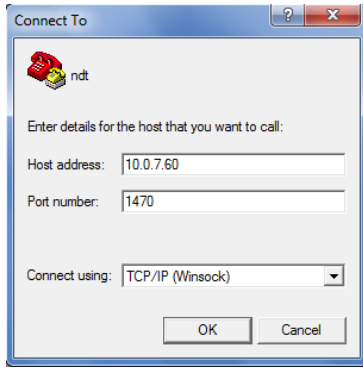

Fig. 27: Terminal Ethernet connection

Firmware upgrade

To upgrade the firmware:

- download from www.caen.it product page the most recent firmware revision for your module
- connect to the module via USB using Tera Term VT Emulator
- in the Tera Term options, select “set up” > “serial port” and enter the following settings

Baud rate:	9600
Data:	8 bit
Parity:	none
Stop:	1 bit
Flow control:	none
Transmit delay	
0	msec/char
1	msec/line

- click OK to confirm
- go to Terminal Board Menu (Fig. 25)
- type U to upgrade the firmware:

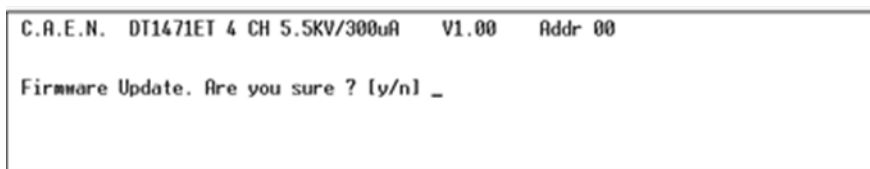

Fig. 28: Firmware Upgrade Menu

- Type y
- the following message will be shown:

```
!!! Checksum Error
Firmware Update...press any key to start
```

- Press any key
- Wait until the following message is shown:

```
Flash Erased!!!
Send file to upload
```

- Select “File” > send file
- Browse the image file
- Select “open”
- Wait the upload to complete
- turn OFF and then ON the module

now the unit is ready to operate running the upgraded firmware

Format EEPROM

By typing F on Terminal Board Menu (Fig. 25) it is possible to access the format EEPROM menu.

```
C.A.E.N. DT1471ET 4 CH 5.5KV/300uA V1.00 Addr 00

Format EEPROM. Are you sure ? [y/n]
```

Fig. 29: Format EEPROM Menu

Channels settings

By typing D on Terminal Board Menu (Fig. 25) it is possible to access channels settings

```
C.A.E.N. DT1471ET 4 CH 5.5KV/300uA Power Supply V1.00 Addr 00

          Ch0          Ch1          Ch2          Ch3
Polarity  -            -            -            -
Vmon      0000.0 V     0000.0 V     0000.0 V     0000.0 V
Imon      000.000 uA   000.000 uA   000.000 uA   000.000 uA
Status    Kill
Power     Off         Off         Off         Off
Vset      1000.0 V     2000.0 V     3000.0 V     2000.0 V
Iset      031.000 uA   310.000 uA   310.000 uA   310.000 uA
Maxv      5600 V      5600 V      5600 V      5600 V
Ramp Up   100 V/S     100 V/S     100 V/S     100 V/S
Ramp Down 200 V/S     200 V/S     200 V/S     200 V/S
Trip      010.0 S     010.0 S     010.0 S     010.0 S
Power Down Kill       Kill       Kill       Kill
Imon Range High      High      High      High

Group Mode  Reset Alarm  Quit
```

Fig. 30: Channels Menu

Board Status

By typing G on Terminal Board Menu (Fig. 25) it is possible to monitor the General Board Status

```
C.A.E.N. DT1470 4 CH 8KV/3mA V1.01 Addr 00

Serial Number      : 48
Local Bus Termination : OFF
Interlock Active   : CLOSED
Internal Supply    : OK
Over Power         : NO
HV Clock Status    : OK

Press 'I' to change Interlock Mode or any key to quit._
```

Fig. 31: General Board Status

Communication Protocol

The following Protocol allows to communicate with up to 32 daisy chained modules. The Protocol is based on commands made of ASCII characters strings.

Command Format

The Format of a command string is the following :

\$BD:,CMD:**,CH*,PAR:**,VAL:**.*<CR, LF >**

The fields that form the command are :

BD : 0..31 module address (to send the command)

CMD : MON, SET

CH : 0..NUMCH (NUMCH=4 for 4 channel units, NUMCH=8 for 8 channel units)

PAR : (see parameters tables)

VAL : (numerical value must have a Format compatible with resolution and range)

Format of response string

Format response in case of error

String	Function (Units)
#BD:**,CMD:ERR	Wrong command Format or command not recognized
#BD:**,CH:ERR	Channel Field not present or wrong Channel value
#BD:**,PAR:ERR	Field parameter not present or parameter not recognized
#BD:**,VAL:ERR	Wrong set value (<Min or >Max)
#BD:**,LOC:ERR	Command SET with module in LOCAL mode

Each string is terminated by < **CR, LF** >

Format response in case of correct command

String	Function (Units)
#BD:**,CMD:OK	command Ok
#BD:**,CMD:OK,VAL:*	command Ok * = value for command to individual Channel
#BD:**,CMD:OK,VAL:*,*,*,*	command Ok *,*,*,* = values Ch0..NUMCH for command to all Channels

Numerical value Field '**VAL**' has Format compatible (comma and decimal part) with the resolution and the range related to the parameter. Each string is terminated by < **CR, LF** >

MONITOR commands related to the Channels

The following table contains the strings to be used to handle monitor commands related to the Channels. The '**X**' in the Field 'Channel' can be set in the '**0..NUMCH**' range.

When '**X=NUMCH**' the module returns the values of the parameter of all Channels.

String	Function (Units)
\$BD:xx,CMD:MON,CH:X,PAR:VSET	Read out VSET value
\$BD:xx,CMD:MON,CH:X,PAR:VMIN	Read out VSET minimum value
\$BD:xx,CMD:MON,CH:X,PAR:VMAX	Read out VSET maximum value
\$BD:xx,CMD:MON,CH:X,PAR:VDEC	Read out VSET number of decimal digits
\$BD:xx,CMD:MON,CH:X,PAR:VMON	Read out VMON value
\$BD:xx,CMD:MON,CH:X,PAR:ISET	Read out ISET value (μ A)
\$BD:xx,CMD:MON,CH:X,PAR:IMIN	Read out ISET minimum value (μ A)
\$BD:xx,CMD:MON,CH:X,PAR:IMAX	Read out ISET max value
\$BD:xx,CMD:MON,CH:X,PAR:ISDEC	Read out ISET number of decimal digits
\$BD:xx,CMD:MON,CH:X,PAR:IMON	Read out IMON value (μ A)
\$BD:xx,CMD:MON,CH:X,PAR:IMRANGE	Read out IMON RANGE value (HIGH / LOW)

String	Function (Units)
\$BD:xx,CMD:MON,CH:X,PAR:IMDEC	Read out IMON number of decimal digits
\$BD:xx,CMD:MON,CH:X,PAR:MAXV	Read out MAXVSET value
\$BD:xx,CMD:MON,CH:X,PAR:MVMIN	Read out MAXVSET minimum value (0 V)
\$BD:xx,CMD:MON,CH:X,PAR:MVMAX	Read out MAXVSET maximum value
\$BD:xx,CMD:MON,CH:X,PAR:MVDEC	Read out MAXVSET number of decimal digits
\$BD:xx,CMD:MON,CH:X,PAR:RUP	Read out RAMP UP value (V/S)
\$BD:xx,CMD:MON,CH:X,PAR:RUPMIN	Read out RAMP UP minimum value (V/S)
\$BD:xx,CMD:MON,CH:X,PAR:RUPMAX	Read out RAMP UP maximum value
\$BD:xx,CMD:MON,CH:X,PAR:RUPDEC	Read out RAMP UP number of decimal digits
\$BD:xx,CMD:MON,CH:X,PAR:RDW	Read out RAMP DOWN value (V/S)
\$BD:xx,CMD:MON,CH:X,PAR:RDWMIN	Read out RAMP DOWN minimum value (V/S)
\$BD:xx,CMD:MON,CH:X,PAR:RDWMAX	Read out RAMP DOWN maximum value
\$BD:xx,CMD:MON,CH:X,PAR:RDWDEC	Read out RAMP DOWN number of decimal digits
\$BD:xx,CMD:MON,CH:X,PAR:TRIP	Read out TRIP time value (S)
\$BD:xx,CMD:MON,CH:X,PAR:TRIPMIN	Read out TRIP time minimum value (S)
\$BD:xx,CMD:MON,CH:X,PAR:TRIPMAX	Read out TRIP time maximum value (S)
\$BD:xx,CMD:MON,CH:X,PAR:TRIPDEC	Read out TRIP time number of decimal digits
\$BD:xx,CMD:MON,CH:X,PAR:PDWN	Read out POWER DOWN value (RAMP / KILL)
\$BD:xx,CMD:MON,CH:X,PAR:POL	Read out POLARITY value ('+' / '-')
\$BD:xx,CMD:MON,CH:X,PAR:STAT	Read out Channel status value (XXXXX)

Meaning of STATUS bits (value read in decimal Format)

Bit	Function
Bit 0 → ON	1 : ON 0 : OFF
Bit 1 → RUP	1 : Channel Ramp UP
Bit 2 → RDW	1 : Channel Ramp DOWN
Bit 3 → OVC	1 : IMON >= ISET
Bit 4 → OVV	1 : VMON > VSET + 2.5 V
Bit 5 → UNV	1 : VMON < VSET - 2.5 V
Bit 6 → MAXV	1 : VOUT in MAXV protection
Bit 7 → TRIP	1 : Ch OFF via TRIP (Imon >= Iset during TRIP)
Bit 8 → OVP	1 : Output Power > Max
Bit 9 → OVT	1: TEMP > 105°C
Bit 10 → DIS	1 : Ch disabled (REMOTE Mode and Switch on OFF position)
Bit 11 → KILL	1 : Ch in KILL via front panel
Bit 12 → ILK	1 : Ch in INTERLOCK via front panel
Bit 13 → NOCAL	1 : Calibration Error
Bit 14, 15 → N.C.	

MONITOR commands related to the module

The following table shows the strings to be used to handle monitor commands related to the module.

String	Function (Units)
\$BD:xx,CMD:MON,PAR:BDNAME	Read out module name
\$BD:xx,CMD:MON,PAR:BDNCH	Read out module Channels number
\$BD:xx,CMD:MON,PAR:BDFREL	Read out Firmware Release
\$BD:xx,CMD:MON,PAR:BDSNUM	Read out module serial number
\$BD:xx,CMD:MON,PAR:BDILK	Read out INTERLOCK status (YES/NO)
\$BD:xx,CMD:MON,PAR:BDILKM	Read out INTERLOCK mode (OPEN/CLOSED)
\$BD:xx,CMD:MON,PAR:BDCTR	Read out Control Mode (LOCAL / REMOTE)

\$BD:xx,CMD:MON,PAR:BDTERM	Read out LOCAL BUS Termination status (ON/OFF)
\$BD:xx,CMD:MON,PAR:BDALARM	Read out Board Alarm status value (XXXXX)

Meaning of Board Alarm bits

Bit	Function
Bit 0 → CH0	1 : Ch0 in Alarm status
Bit 1 → CH1	1 : Ch1 in Alarm status
Bit 2 → CH2	1 : Ch2 in Alarm status
Bit 3 → CH3	1 : Ch3 in Alarm status
Bit 4 → PWFAIL	1 : Board in POWER FAIL
Bit 5 → OVP	1 : Board in OVER POWER
Bit 6 → HVCKFAIL	1 : Internal HV Clock FAIL (≠ 200±10kHz)

SET commands related to the Channels

The following table contains the strings to be used to handle set commands related to the Channels. The 'X' in the Field 'Channel' can be set to the '0..NUMCH' range. When 'X=NUMCH' the command is issued to all Channels.

String	Function (Units)
\$BD:xx,CMD:SET,CH:X,PAR:VSET,VAL:value	Set VSET value
\$BD:xx,CMD:SET,CH:X,PAR:ISET,VAL:value	Set ISET value
\$BD:xx,CMD:SET,CH:X,PAR:MAXV,VAL:value	Set MAXVSET value
\$BD:xx,CMD:SET,CH:X,PAR:RUP,VAL:value	Set RAMP UP value
\$BD:xx,CMD:SET,CH:X,PAR:RDW,VAL:value	Set RAMP DOWN value
\$BD:xx,CMD:SET,CH:X,PAR:TRIP,VAL:value	Set TRIP time value
\$BD:xx,CMD:SET,CH:X,PAR:PDWN,VAL:RAMP/KILL	Set POWER DOWN mode
\$BD:xx,CMD:SET,CH:X,PAR:IMRANGE,VAL:HIGH/LOW	Set IMON RANGE
\$BD:xx,CMD:SET,CH:X,PAR:ON	Set Ch ON
\$BD:xx,CMD:SET,CH:X,PAR:OFF	Set Ch OFF

SET commands related to the module

String	Function (Units)
\$BD:xx,CMD:SET,PAR:BDILKM,VAL:OPEN/CLOSED	Set Interlock Mode
\$BD:xx,CMD:SET,PAR:BDCLR	Clear alarm signal

EPICS Service

EPICS (Experimental Physics and Industrial Control System) is a set of software tools and applications which provide a software infrastructure for use in building distributed control systems, widely used to control experimental Physics and industrial electronics.

CAEN provides EPICS Input/Output Controller (IOC) for 19" and DeskTop HV Power Supplies, that allows access to a Process Variable using the Channel Access Protocol. Process Variable is a named piece of data associated with the module (e.g. status, readback, setpoint, parameter).

Client software (EPICS Channel Access Client), which requests access to a Process Variable, runs on the Host PC and is connected to the modules via either TCP/IP or USB.

The EPICS IOC is available for free download on www.caen.it website (Power Supply Software section)

More information about EPICS and a list of available client applications can be found at:

<http://www.aps.anl.gov/epics/>.

4. Internal Settings

Polarity selection

The output polarity is independently selectable for each channel. Note that the polarity is indicated by two LEDs for each channel on the front panel (see p. 9).

To change the polarity:

- Wear Antistatic Gloves
- Switch off the unit
- Wait for the complete discharge of the capacitors.
 - Desktop: Remove screws that keep in place the top cover;
 - 19": Remove screws that keep in place the top cover (six lateral, and one front)
- Lift the top cover gently
- Remove screws that keep in place the protection bar:

14xx series

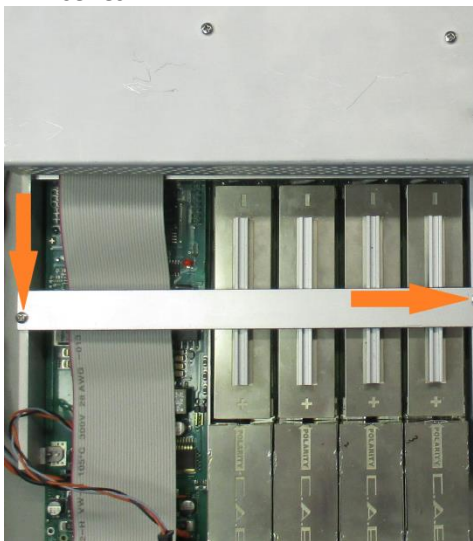

1570 series

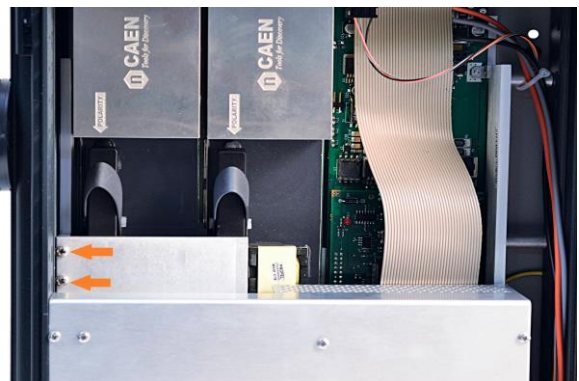

- Remove the bar

At this point it is possible to change the channel polarity: refer to the following figure (the blue arrow indicates diode bridge box placed to configure channel as POSITIVE).

During this operation pay attention not to bend the pins, when plugging them completely in their sockets



14xx series

1570 series

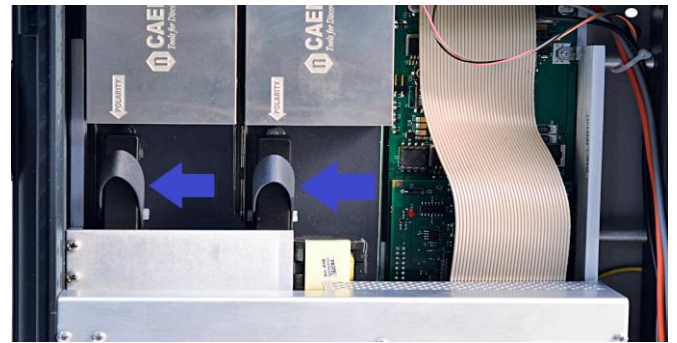
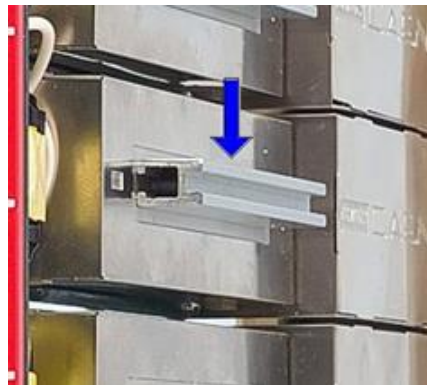

Fig. 32: Polarity selection instructions

- To choose the POSITIVE POLARITY, plug the diode bridge box, with the + symbol towards the connector side.
- To choose the NEGATIVE POLARITY, plug the diode bridge box, with the - symbol towards the connector side.
- Always pull and plug the diode bridge box by holding it on the handle pointed by the arrow in Fig. above.
- Once settings are done, put the bars (insulated side towards diode boxes) and covers back in place with the screws

Grounding specifications

The unit's channels share a common floating return (FAGND), insulated from the crate ground (AGND). This feature allows on-detector grounding, thus avoiding loops which may increase noise level. FAGND and AGND may be connected, by short circuiting C21 jumper pins on the motherboard (see figure below). The protection shield must be screwed off to access C21 (see p.27 Polarity selection).

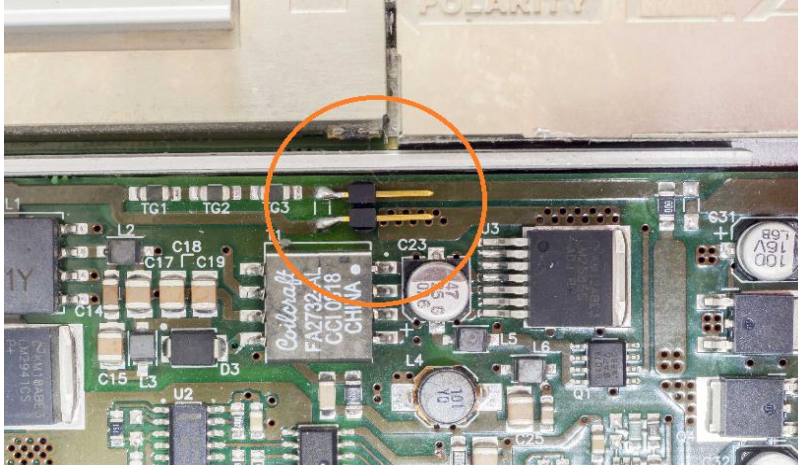

Fig. 33: C21 jumper location

Safety Earth connection

The connection of return to Earth is fundamental for User safety. The connection must always be at the level of detector or power supply system.

Return connection even if not present or performed incorrectly, due to protection circuits implemented on the unit, are bound to Earth; in this case the voltage difference between return and Earth (System), is limited to approximately 50V. Please note that this is a status of emergency-protection, not a working one. The Connector Configurator allows to optimize the connection of the return and of AGND (Earth). The best configuration must be determined by the user upon application, the optimal connection depends on many characteristics of the related experiment.

The following diagrams show two examples of configuration, namely:

1. The "closed loop" Earth configuration (C21 contacts closed)
2. The "open loop" Earth configuration (C21 contacts open)

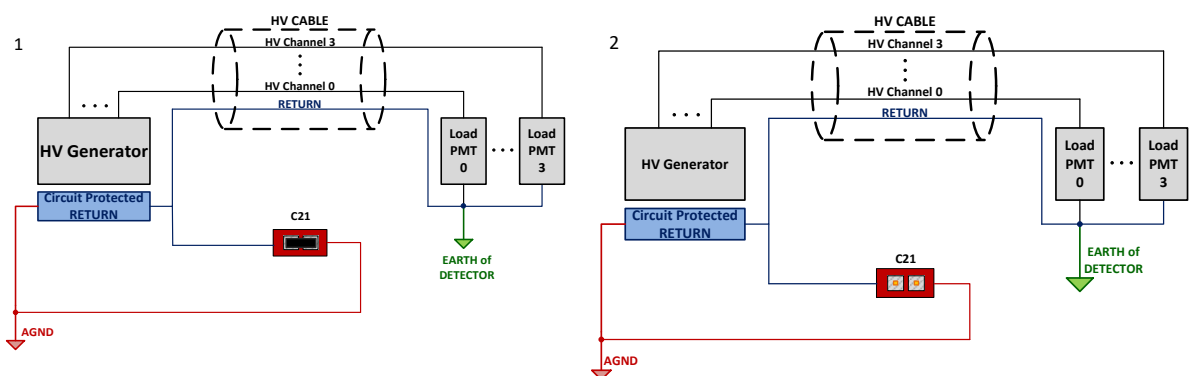

Fig. 34: Earth configuration connection examples



CAEN SpA is acknowledged as the only company in the world providing a complete range of High/Low Voltage Power Supply systems and Front-End/Data Acquisition modules which meet IEEE Standards for Nuclear and Particle Physics. Extensive Research and Development capabilities have allowed CAEN SpA to play an important, long term role in this field. Our activities have always been at the forefront of technology, thanks to years of intensive collaborations with the most important Research Centres of the world. Our products appeal to a wide range of customers including engineers, scientists and technical professionals who all trust them to help achieve their goals faster and more effectively.

**CAEN S.p.A.**

Via Vetraia, 11
55049 Viareggio
Italy
Tel. +39.0584.388.398
Fax +39.0584.388.959
info@caen.it
www.caen.it

CAEN GmbH

Eckehardweg 10
42653 Solingen
Germany
Tel. +49.212.2544077
Mobile +49(0)15116548484
Fax +49.212.2544079
info@caen-de.com
www.caen-de.com

CAEN Technologies, Inc.

1140 Bay Street - Suite 2 C
Staten Island, NY 10305
USA
Tel. +1.718.981.0401
Fax +1.718.556.9185
info@caentechnologies.com
www.caentechnologies.com